

# TECNA<sup>®</sup>

Resistance Welding Systems & Balancers

**robot spot welding guns**



[www.tecna.net](http://www.tecna.net)

# 2933

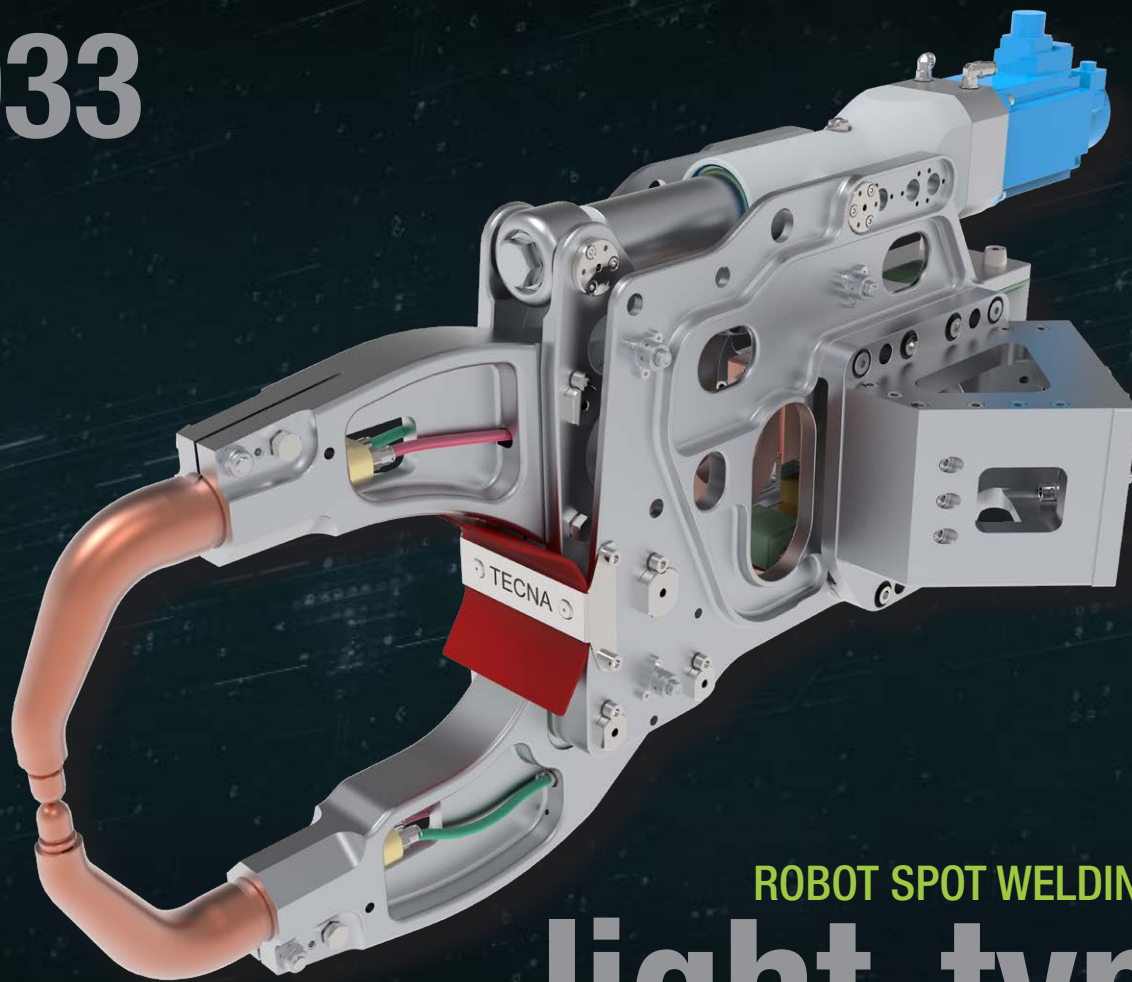

ROBOT SPOT WELDING GUN

# light-type

ACTUATOR TECNA AND SERVMOTOR OF ROBOT MANUFACTURER

### general data

		Actuator sizes		
Welding force, N	Arm length	6 Nm	9,5 Nm	11 Nm
	300 mm	8000 N	8500 N	9500 N
	450 mm	5500 N	7500 N	8500 N
	600 mm	4200 N	6500 N	7500 N

### motor

	Servomotor speed	3000 rpm		
Gun mass		82 kg	86 kg	87 kg

### transformer

Type	MFDC 90 kVA 400V/50 Hz Light	MFDC 90 kVA 480V/60 Hz Light
S1P	63,6 kVA	63,6 kVA
U20	9,1 V	9,1 V
I2P *	6 kA	6 kA
U1N	500 V / 1000 Hz	635 V / 1000 Hz
weight	16 kg	16 kg
Water Cooling	4 l/min	4 l/min

# 2934

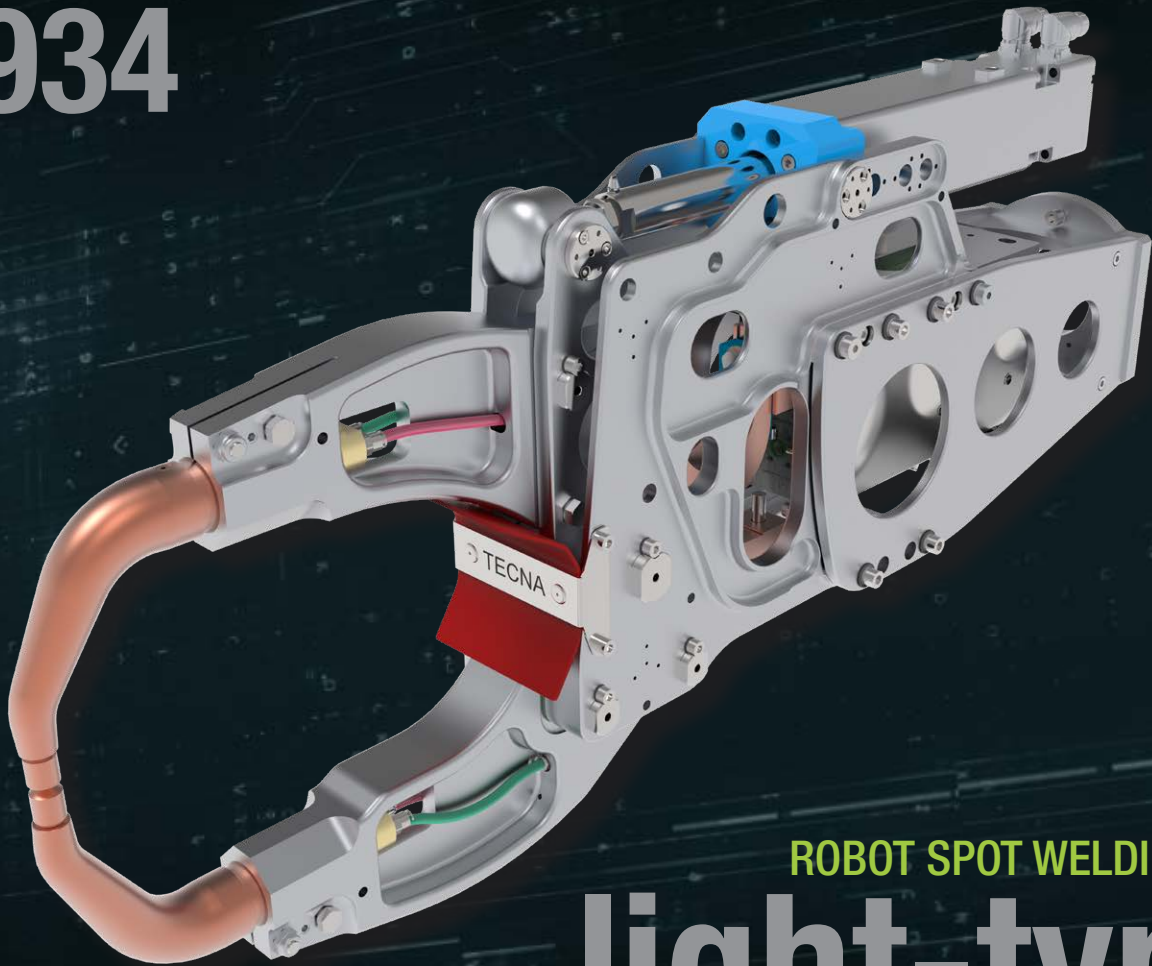

ROBOT SPOT WELDING GUN  
**light-type**  
 INVERTED ROLLER SCREW ACTUATORS

general data				
		Actuator sizes	EXLAR GTW100	TOLOMATIC CSWX-4
Welding force	Arm length		12 Nm	11 Nm
	300 mm		10000 N	9500 N
	450 mm		9000 N	8000 N
	600 mm		8000 N	7000 N

motor				
		Servomotor speed	3000 rpm	
Gun mass			83 kg	82 kg

transformer			
Type		MFDC 90 kVA 400V/50 Hz Light	MFDC 90 kVA 480V/60 Hz Light
S1P		63,6 kVA	63,6 kVA
U20		9,1 V	9,1 V
I2P *		6 kA	6 kA
U1N		500 V / 1000 Hz	635 V / 1000 Hz
weight		16 kg	16 kg
Water Cooling		4 l/min	4 l/min



# 2943

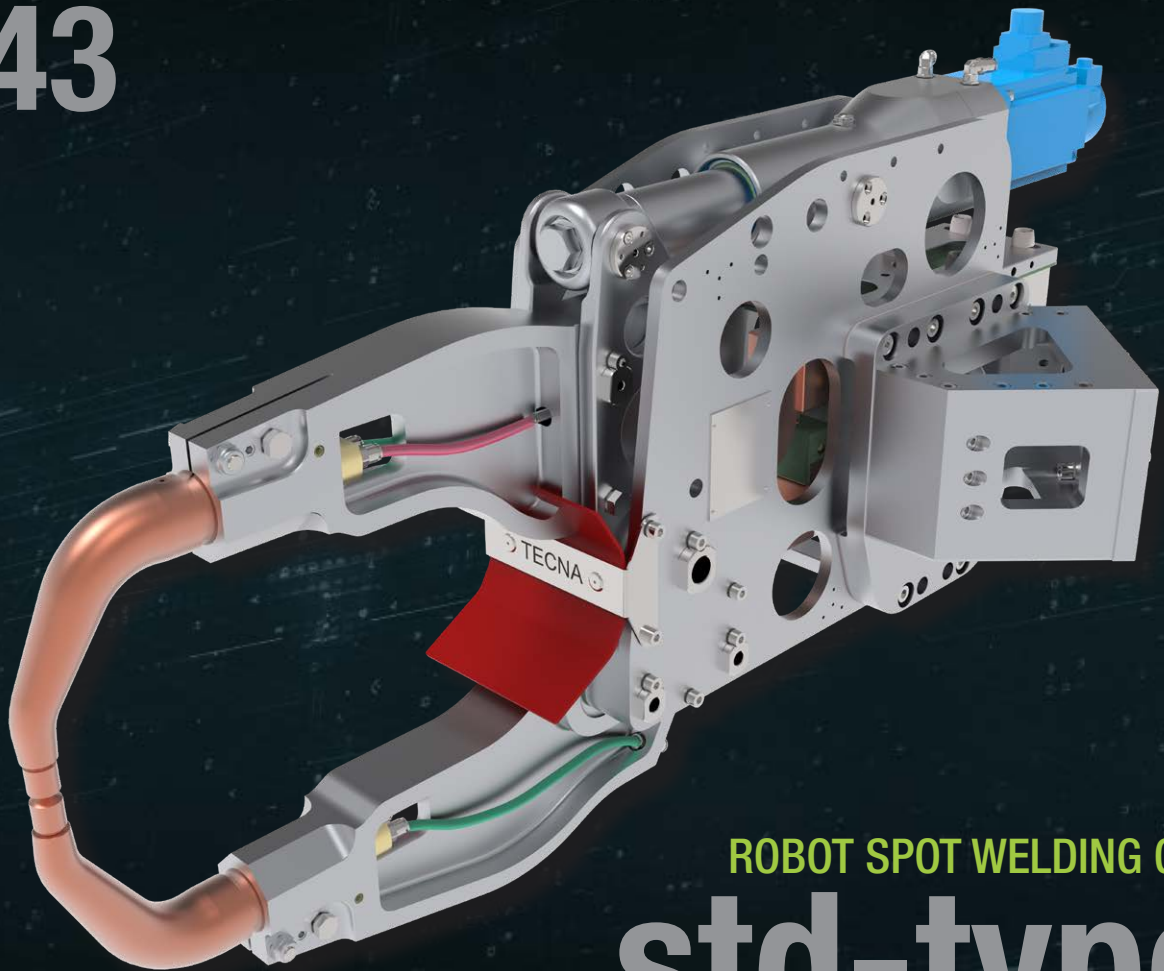

## ROBOT SPOT WELDING GUN std-type

ACTUATOR TECNA AND SERVMOTOR OF ROBOT MANUFACTURER

### general data

		Actuator sizes		
Welding force	Arm lenght	6 Nm	9,5 Nm	11 Nm
	300 mm	8000 N	8500 N	9500 N
	450 mm	5500 N	7500 N	8500 N
	600 mm	4200 N	6500 N	7500 N

### motor

	Servomotor speed	3000 rpm		
Gun mass		91 kg	97 kg	97 kg

### transformer

Type	MFDC 90 kVA 400V/50 Hz Heavy	MFDC 90 kVA 480V/60 Hz Heavy
S1P	63,6 kVA	63,6 kVA
U20	9,1 V	9,1 V
I2P *	6,75 kA	6,75 kA
U1N	500 V / 1000 Hz	635 V / 1000 Hz
weight	17,5 kg	17,5 kg
Water Cooling	4 l/min	4 l/min

# 2944

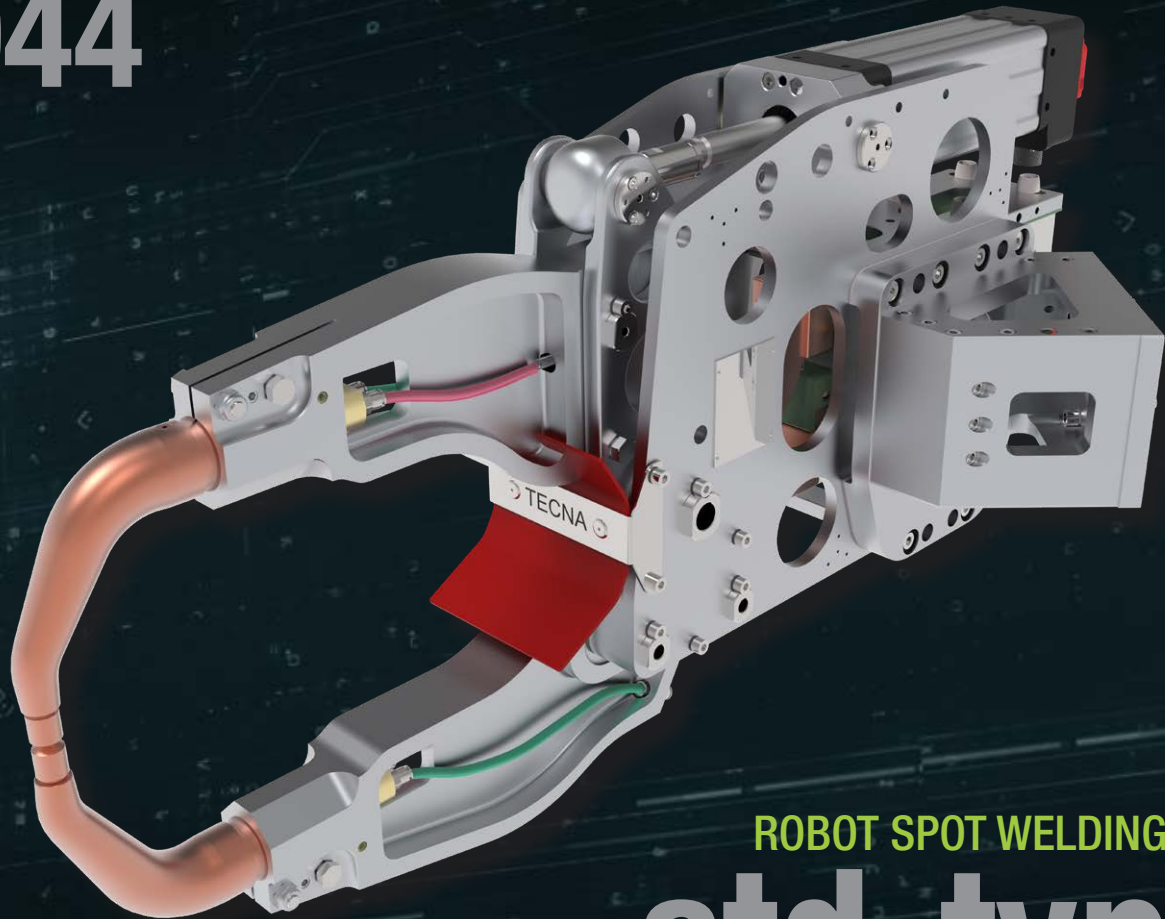

ROBOT SPOT WELDING GUN  
**std-type**  
 INVERTED ROLLER SCREW ACTUATORS

**general data**

		Actuator sizes	EXLAR GTW100	TOLOMATIC CSWX-4
Welding force	Arm length		12 Nm	11 Nm
	300 mm		10000 N	9500 N
	450 mm		9000 N	8000 N
	600 mm		8000 N	7000 N

**motor**

		Servomotor speed	3000 rpm	
Gun mass			90 kg	89 kg

**transformer**

Type	MFDC 90 kVA 400V/50 Hz Heavy	MFDC 90 kVA 480V/60 Hz Heavy
S1P	63,6 kVA	63,6 kVA
U20	9,1 V	9,1 V
I2P *	6,75 kA	6,75 kA
U1N	500 V / 1000 Hz	635 V / 1000 Hz
weight	17,5 kg	17,5 kg
Water Cooling	4 l/min	4 l/min

# GUN COUPLING TO ROBOT

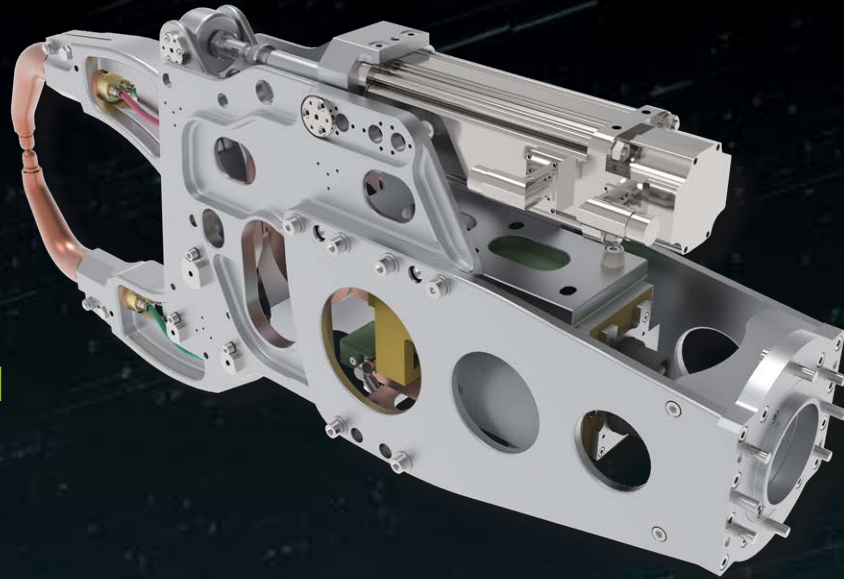

REAR CONNECTION

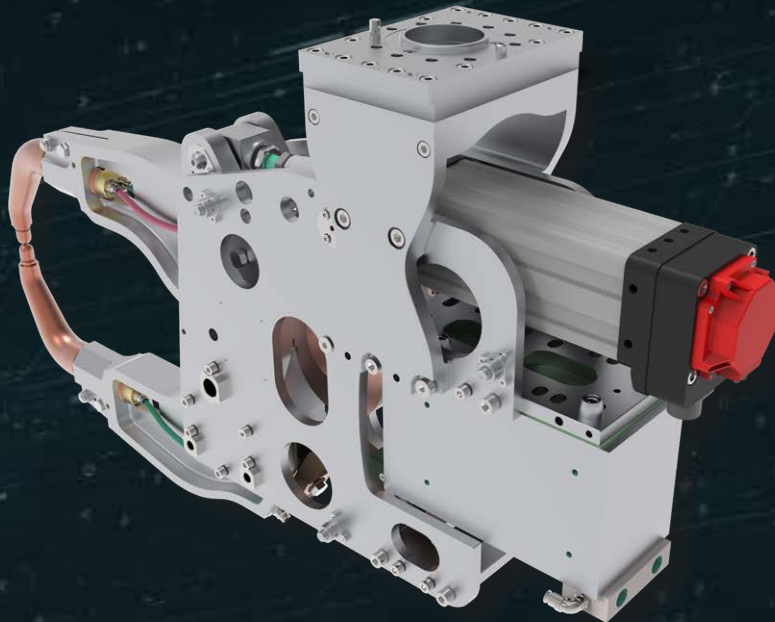

TOP CONNECTION

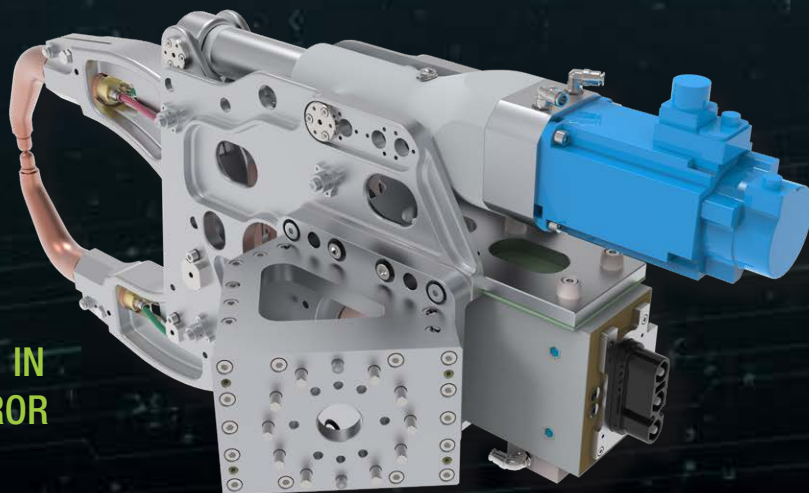

45° CONNECTION  
EVERY GUNS IS AVAIBLE IN  
ITS RIGHT OR LEFT MIRROR  
CONFIGURATION AND  
SYMMETRICAL GUNS



# TYPE OF SERVO MOTOR

## THIRD PART MOTOR

Exlar model: GTW100

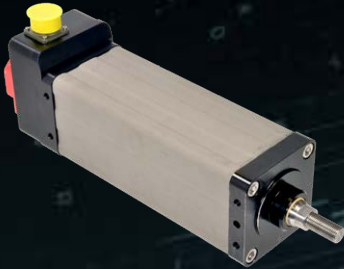

Tolomatic model: CSW

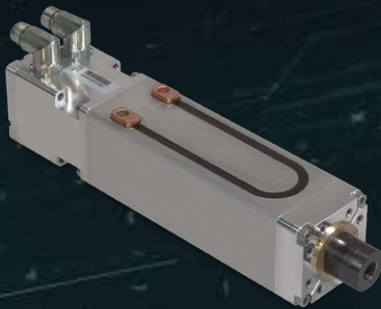

Diakont model: DA99

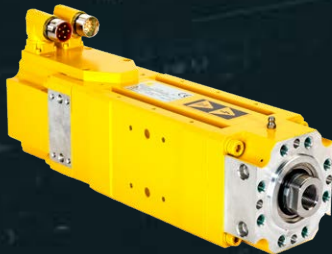

## ACTUATOR TECNA AND SERVO MOTOR OF ROBOT MANUFACTURER

Yaskawa model: SGM7A-20A

2 kW \_ 6,36 Nm \_ 6,8 kg



Fanuc model: BiS12-3000 B

1,8 kW \_ 11 Nm \_ 11,9 kg



Abb model: MU200

6,4 Nm \_ 10,3 kg



Kawasaki model: R2AA13200 LCP2S

2 kW \_ 9,5 Nm



Hyundai model: TSM3508

3,7 kW \_ 11,7 Nm \_ 11,9 kg

Kuka model: MG110-130

2,4 kW \_ 5,8 Nm \_ 13,8 kg

Nachi model: W-L02152

2 kW \_ 9,5 Nm \_ 12 kg

# OPTIONS

**ACTUATOR LOAD CELL**  
ONLY FOR LIGHT-TYPE WELDING GUN  
2933/2934



**COOLING SERVOMOTOR**



# WELDING ARMS CONFIGURATION

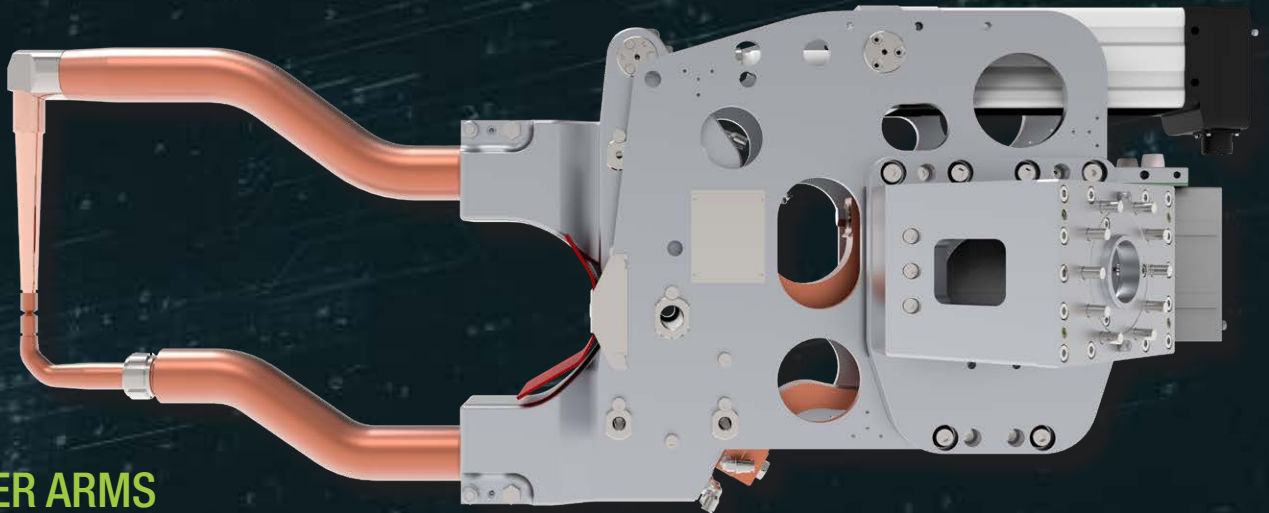

**COPPER ARMS**

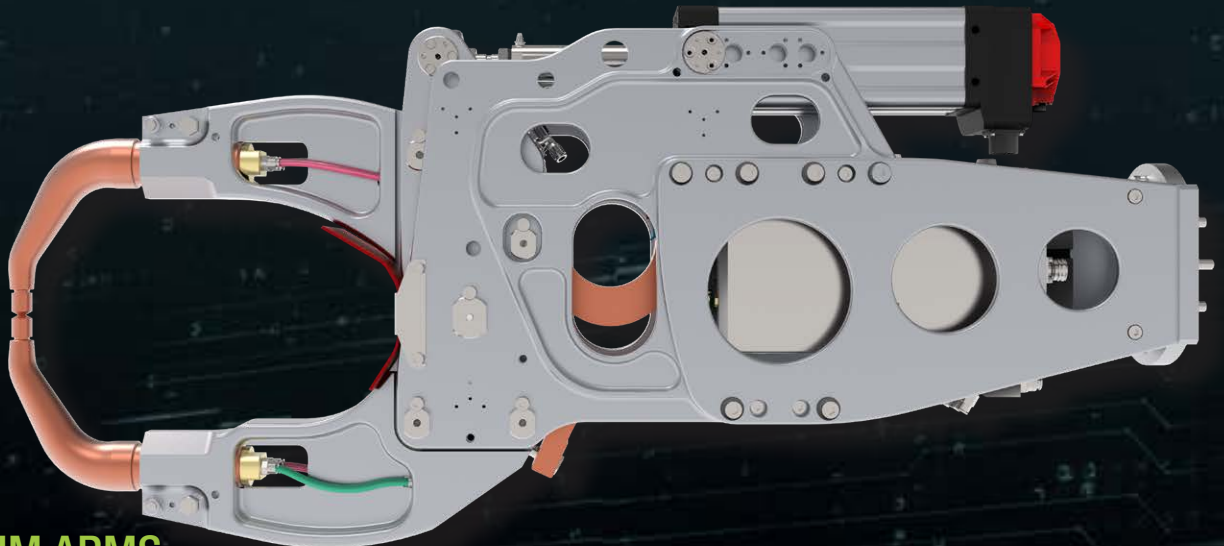

**ALUMINUM ARMS**

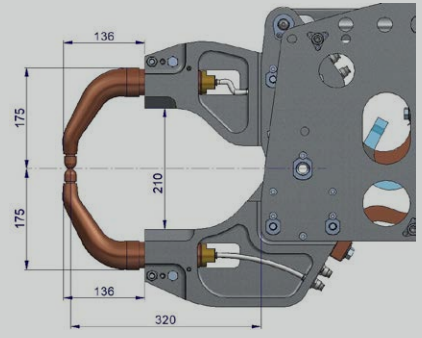
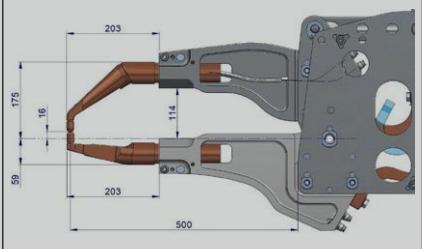
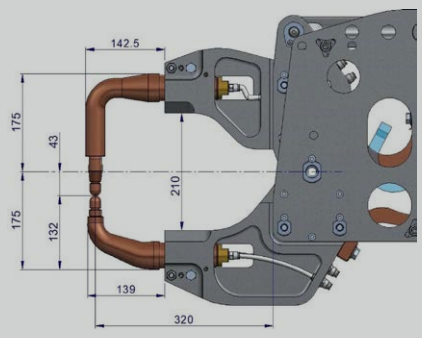
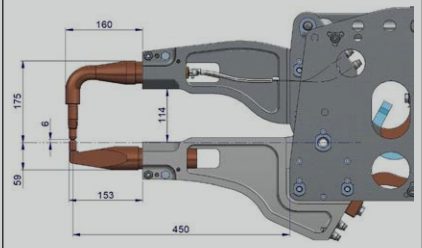
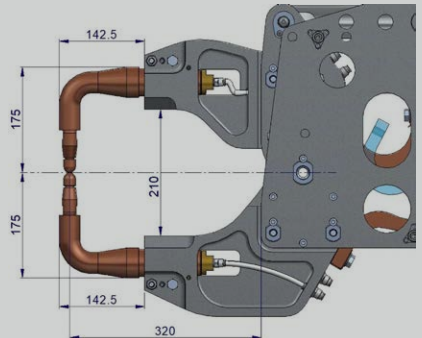
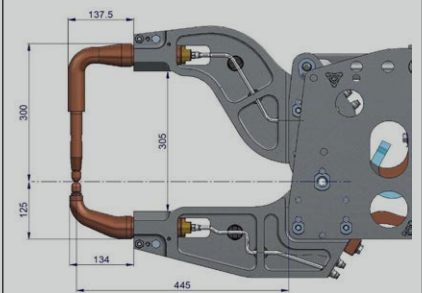
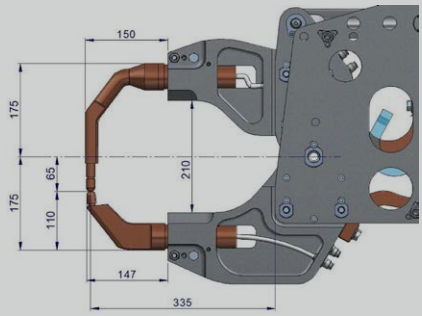
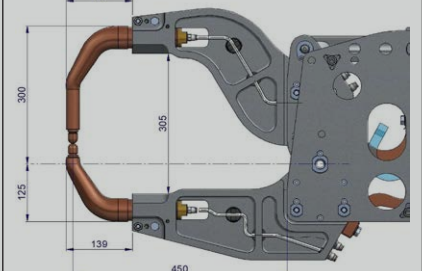
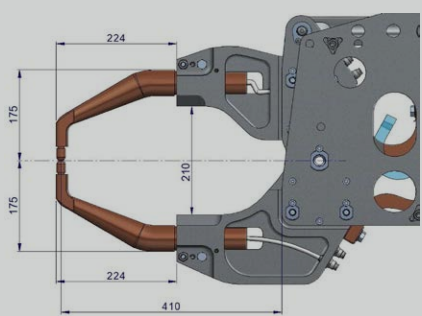
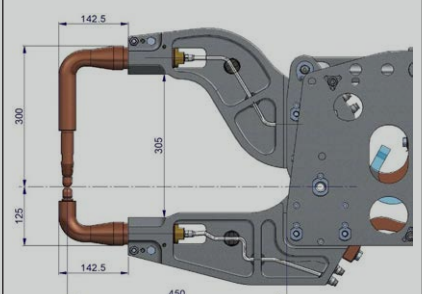

# WELDING ARMS CONFIGURATION

SLIMLINEROBOTGUNARM&HOLDERVARIANTS			
Designcode	Designshape	Designcode	Designshape
X-300X200-D16-V1		X-450X114-V1	
X-300X200-D16-V2		X-450X114-V2	
X-300X200-D16-V3		X-450X300-V1	
X-300X200-D16-V4		X-450X300-V2	
X-300X200-D16-V5		X-450X300-V3	

# WELDING ARMS CONFIGURATION

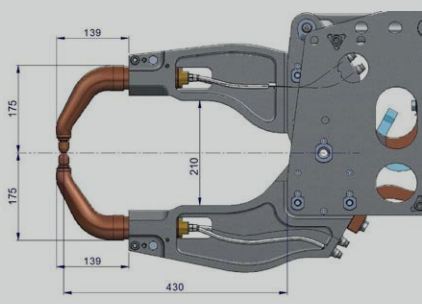
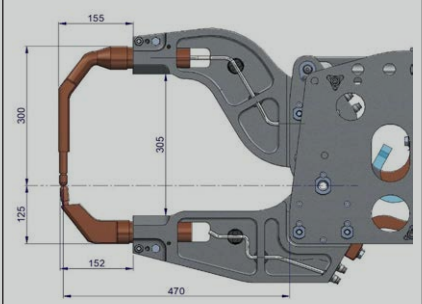
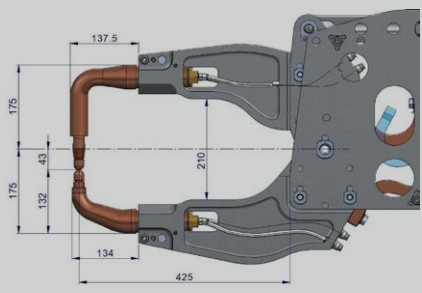
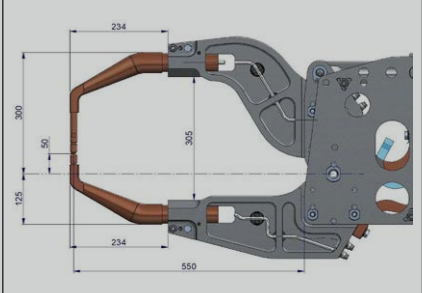
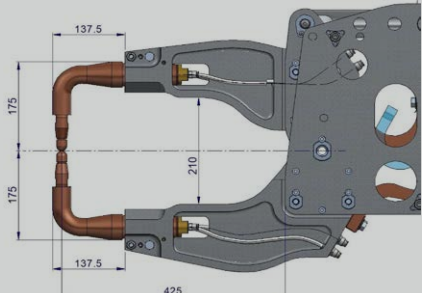
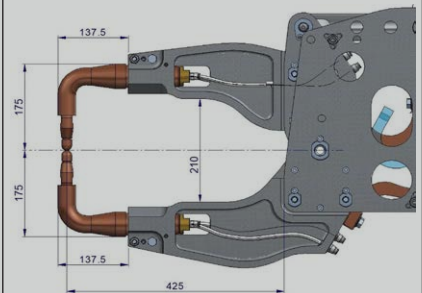
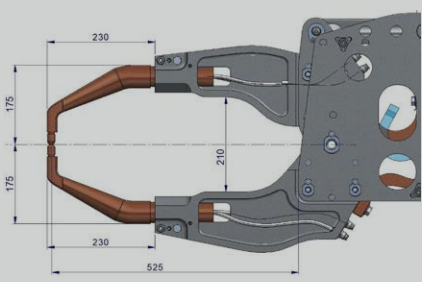
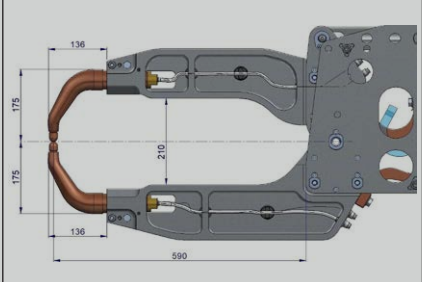
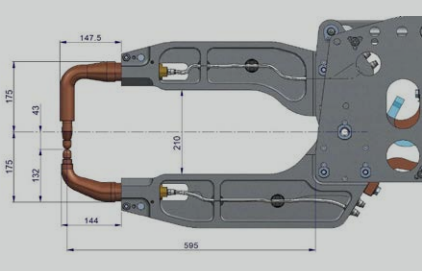
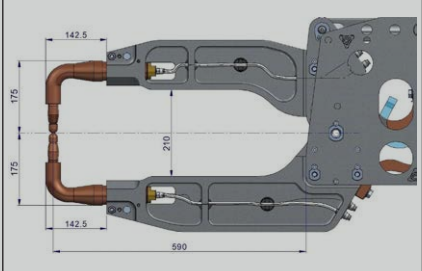
SLIMLINEROBOTGUNARM&HOLDERVARIANTS			
Designcode	Designshape	Designcode	Designshape
X-450X200-D16-V1		X-450X300-V4	
X-450X200-D16-V2		X-450X300-V5	
X-450X200-D16-V3		X-450X200-D16-V4	
X-450X200-D16-V5		X-600X200-D16-V1	
X-600X200-D16-V2		X-600X200-D16-V3	

# WELDING ARMS CONFIGURATION

SLIMLINEROBOTGUNARM&HOLDERVARIANTS			
Designcode	Designshape	Designcode	Designshape
X-600X200-D16-V4		X-600X200-D16-V5	
X-300X114-D16-V1		X-600X114-D16-V1	
X-300X114-D16-V2		X-600X114-D16-V2	





**TECNA**<sup>®</sup>  
Resistance Welding Systems & Balancers

Via Meucci, 27  
40024 - Castel S. Pietro Terme (BO)  
Italy

Tel. +39 051 695 4411

Fax +39 051 695 4490

[www.tecna.net](http://www.tecna.net)

[vendite@tecna.net](mailto:vendite@tecna.net)

[sales@tecna.net](mailto:sales@tecna.net)

