

TECNA®

Via Grieco 25/27 - 40024 Castel S. Pietro Terme - (BO) - ITALY
Tel. +39.051.6954411 - Fax +39.051.6954490
http://www.tecna.net E-mail: sales@tecna.net

SALDATRICI TRIFASI A CORRENTE CONTINUA PER INDUSTRIA AERONAUTICA E MILITARE, DERIVATE DALLA SERIE, CON CONTROLLO A CORRENTE COSTANTE, STRUTTURE AD ALTA RIGIDITA', CICLO DI PRESSIONE COMPLETO E A RICHIESTA VALVOLA PROPORZIONALE, CILINDRO CON GUIDA A RULLI E MONITORAGGIO DEI PARAMETRI DI SALDATURA (es. CORRENTE, PRESSIONE, FORZA, TENSIONE RETE, FREQUENZA E TEMPERATURA)



DC THREE-PHASE WELDERS FOR AIRCRAFT AND MILITARY INDUSTRIES, DEVELOPPED FROM STANDARD MACHINES EQUIPPED WITH CONSTANT CURRENT CONTROL UNIT, HIGHLY RIGID FRAMES, COMPLETE PRESSURE CYCLE, PROPORTIONAL VALVE UPON DEMAND, ROLLER-GUIDED CYLINDER, WELDING PARAMETERS MONITORING (I.E.: CURRENT, PRESSURE, FORCE, MAINS VOLTAGE, FREQUENCY AND TEMPERATURE).

L=1200 - 250 kVA - 3388 daN

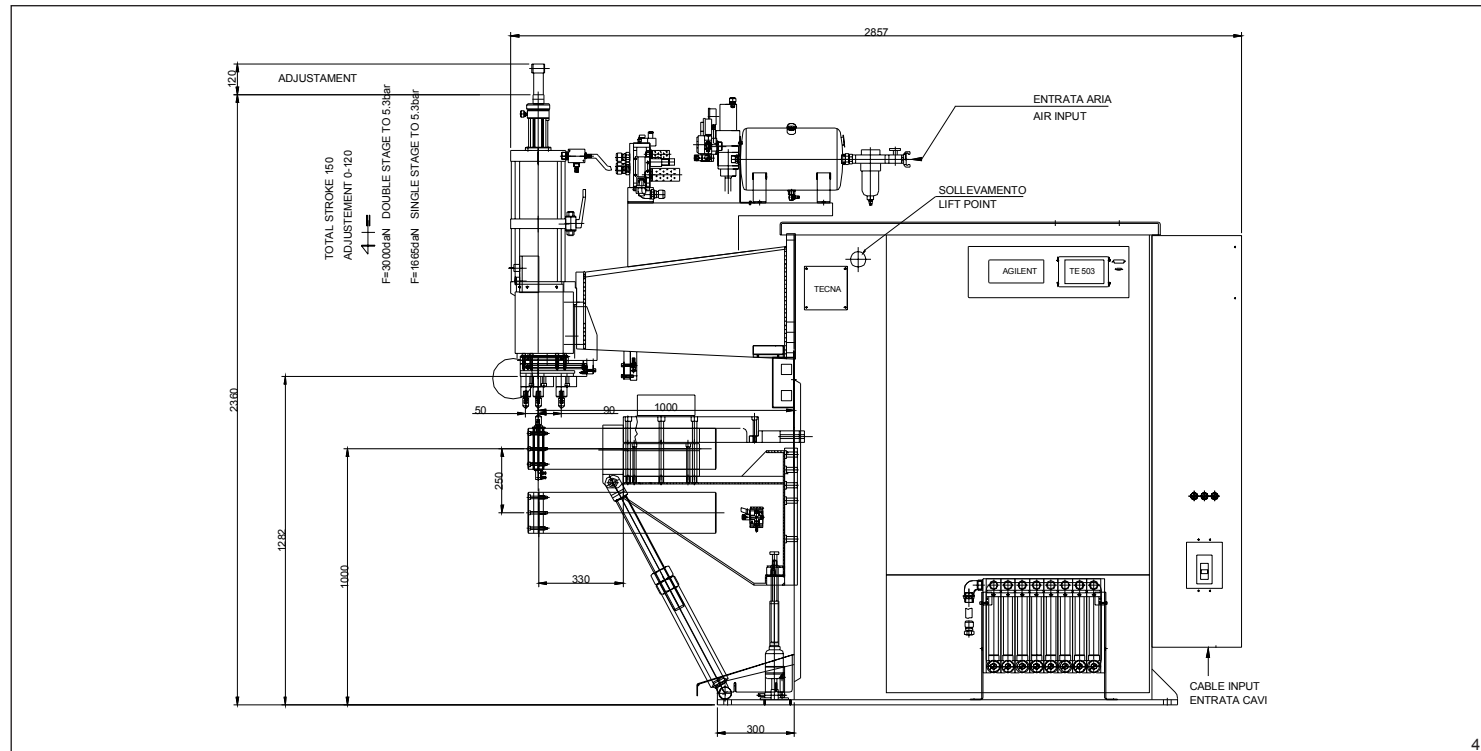

TECNA®

Via Grieco 25/27 - 40024 Castel S. Pietro Terme - (BO) - ITALY
Tel. +39.051.6954411 - Fax +39.051.6954490
http://www.tecna.net E-mail: sales@tecna.net

SALDATRICI TRIFASI A CORRENTE CONTINUA PER INDUSTRIA AERONAUTICA E MILITARE, DERIVATE DALLA SERIE, CON CONTROLLO A CORRENTE COSTANTE, STRUTTURE AD ALTA RIGIDITA', CICLO DI PRESSIONE COMPLETO E A RICHIESTA VALVOLA PROPORZIONALE, CILINDRO CON GUIDA A RULLI E MONITORAGGIO DEI PARAMETRI DI SALDATURA (es. CORRENTE, PRESSIONE, FORZA, TENSIONE RETE, FREQUENZA E TEMPERATURA)

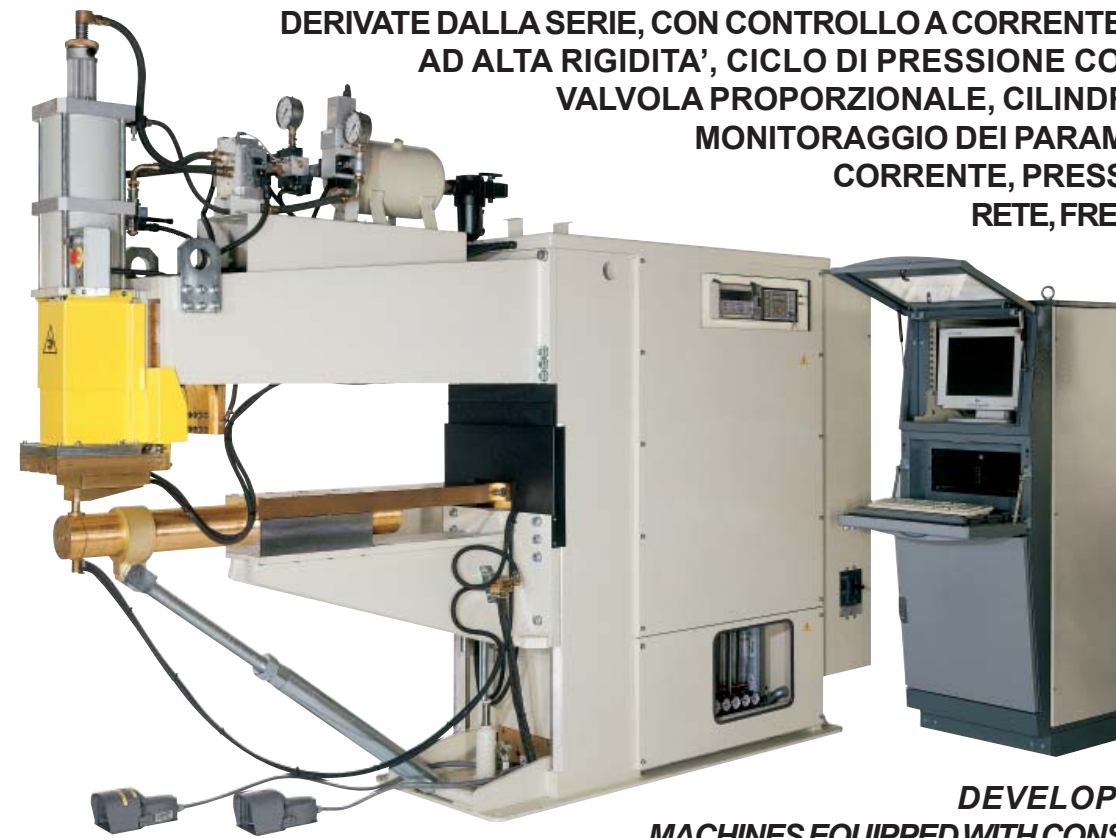

DC THREE-PHASE WELDERS FOR AIRCRAFT AND MILITARY INDUSTRIES, DEVELOPPED FROM STANDARD MACHINES EQUIPPED WITH CONSTANT CURRENT CONTROL UNIT, HIGHLY RIGID FRAMES, COMPLETE PRESSURE CYCLE, PROPORTIONAL VALVE UPON DEMAND, ROLLER-GUIDED CYLINDER, WELDING PARAMETERS MONITORING (I.E.: CURRENT, PRESSURE, FORCE, MAINS VOLTAGE, FREQUENCY AND TEMPERATURE).

L=1500 - 400 kVA - 3388 daN

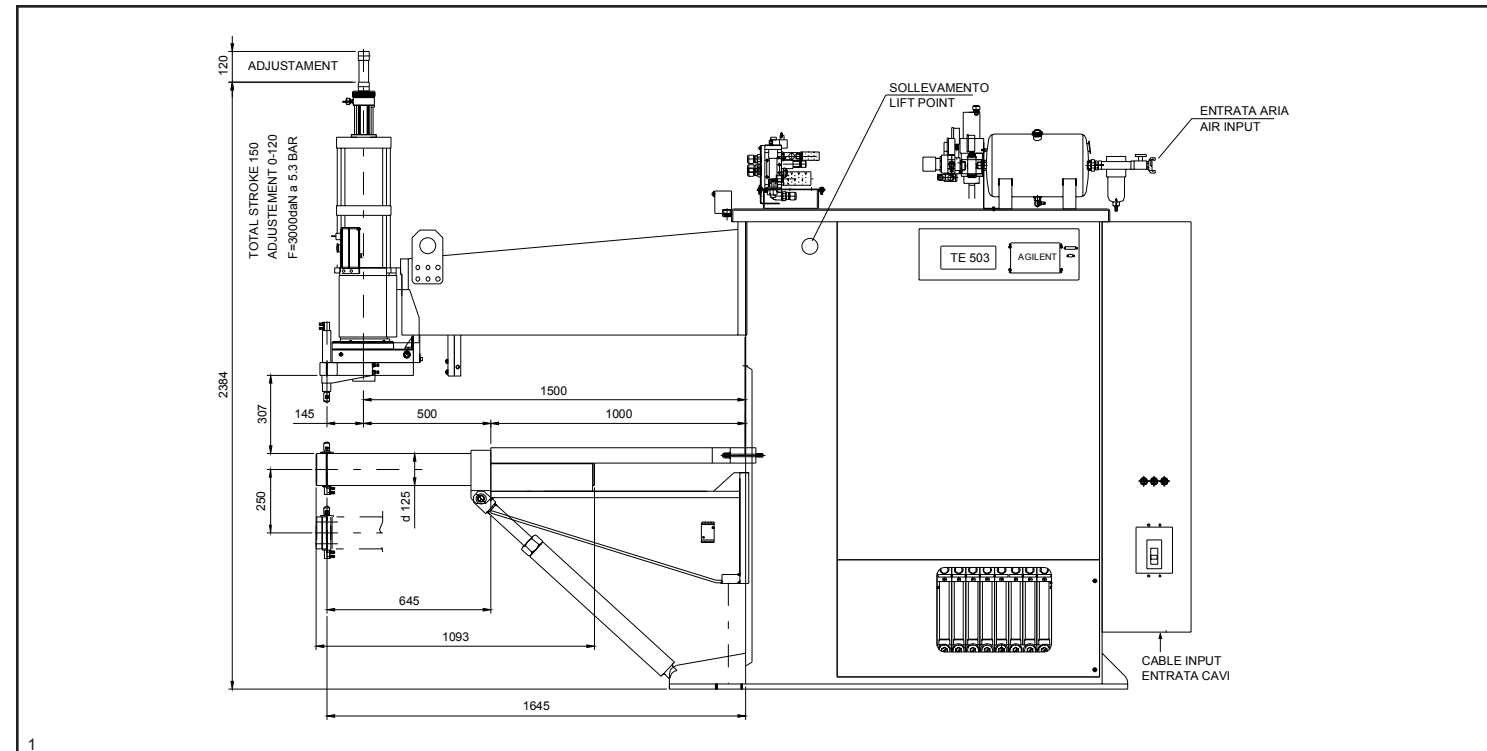

TECNA®

Via Grieco 25/27 - 40024 Castel S. Pietro Terme - (BO) - ITALY
Tel. +39.051.6954411 - Fax +39.051.6954490
http://www.tecna.net E-mail: sales@tecna.net

SALDATRICI TRIFASI A CORRENTE CONTINUA PER INDUSTRIA AERONAUTICA E MILITARE, DERIVATE DALLA SERIE, CON CONTROLLO A CORRENTE COSTANTE, STRUTTURE AD ALTA RIGIDITA', CICLO DI PRESSIONE COMPLETO E A RICHIESTA VALVOLA PROPORZIONALE, CILINDRO CON GUIDA A RULLI E MONITORAGGIO DEI PARAMETRI DI SALDATURA (es. CORRENTE, PRESSIONE, FORZA, TENSIONE RETE, FREQUENZA E TEMPERATURA)



DC THREE-PHASE WELDERS FOR AIRCRAFT AND MILITARY INDUSTRIES, DEVELOPPED FROM STANDARD MACHINES EQUIPPED WITH CONSTANT CURRENT CONTROL UNIT, HIGHLY RIGID FRAMES, COMPLETE PRESSURE CYCLE, PROPORTIONAL VALVE

UPON DEMAND, ROLLER-GUIDED CYLINDER, WELDING PARAMETERS MONITORING (I.E.: CURRENT, PRESSURE, FORCE, MAINS VOLTAGE, FREQUENCY AND TEMPERATURE).

L=500 - 50/100 kVA - 1206 daN

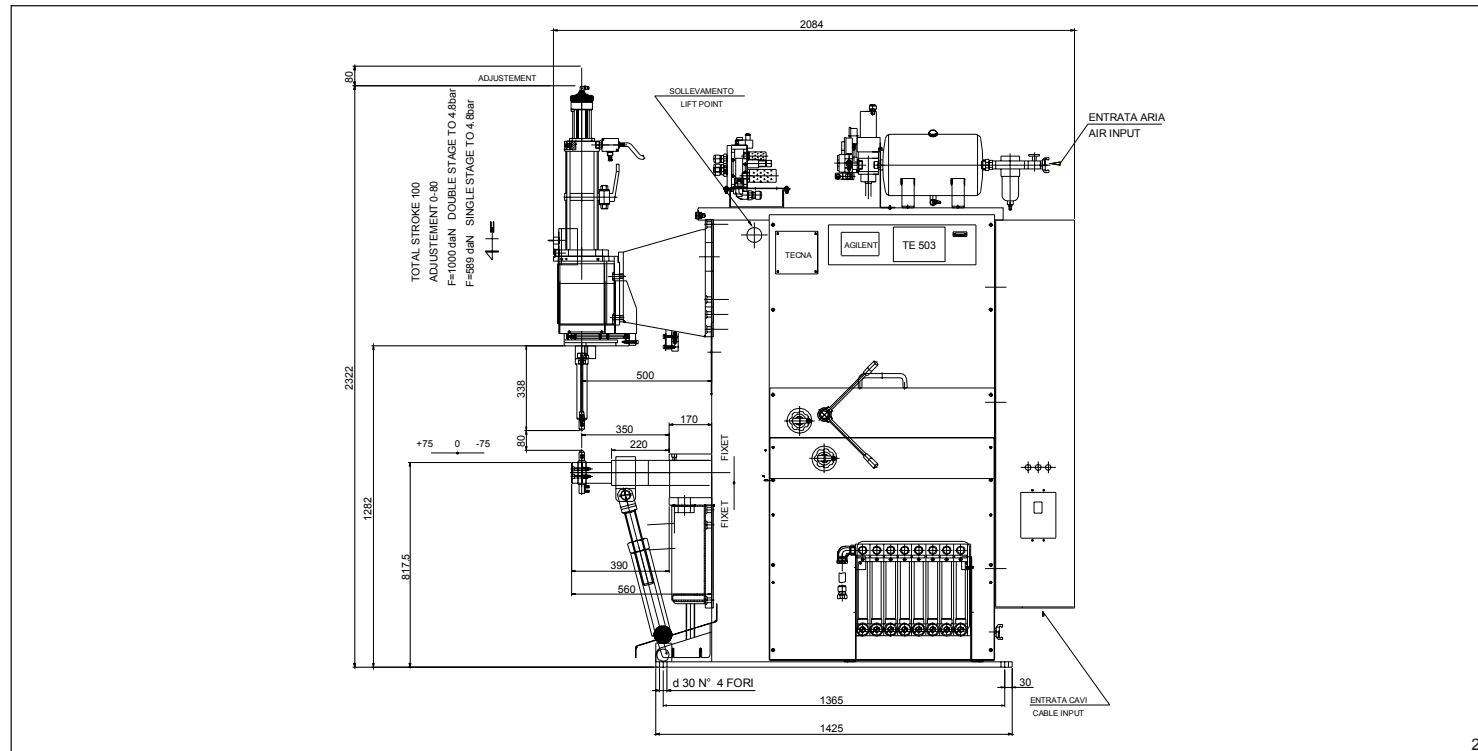

2

TECNA®

Via Grieco 25/27 - 40024 Castel S. Pietro Terme - (BO) - ITALY
Tel. +39.051.6954411 - Fax +39.051.6954490
http://www.tecna.net E-mail: sales@tecna.net

SALDATRICI TRIFASI A CORRENTE CONTINUA PER INDUSTRIA AERONAUTICA E MILITARE, DERIVATE DALLA SERIE, CON CONTROLLO A CORRENTE COSTANTE, STRUTTURE AD ALTA RIGIDITA', CICLO DI PRESSIONE COMPLETO E A RICHIESTA VALVOLA PROPORZIONALE, CILINDRO CON GUIDA A RULLI E MONITORAGGIO DEI PARAMETRI DI SALDATURA (es. CORRENTE, PRESSIONE, FORZA, TENSIONE RETE, FREQUENZA E TEMPERATURA)



DC THREE-PHASE WELDERS FOR AIRCRAFT AND MILITARY INDUSTRIES, DEVELOPPED FROM STANDARD MACHINES EQUIPPED WITH CONSTANT CURRENT CONTROL UNIT, HIGHLY RIGID FRAMES, COMPLETE PRESSURE CYCLE, PROPORTIONAL VALVE UPON DEMAND, ROLLER-GUIDED

CYLINDER, WELDING PARAMETERS MONITORING (I.E.: CURRENT, PRESSURE, FORCE, MAINS VOLTAGE, FREQUENCY AND TEMPERATURE).

L=800 - 160 kVA - 1885 daN

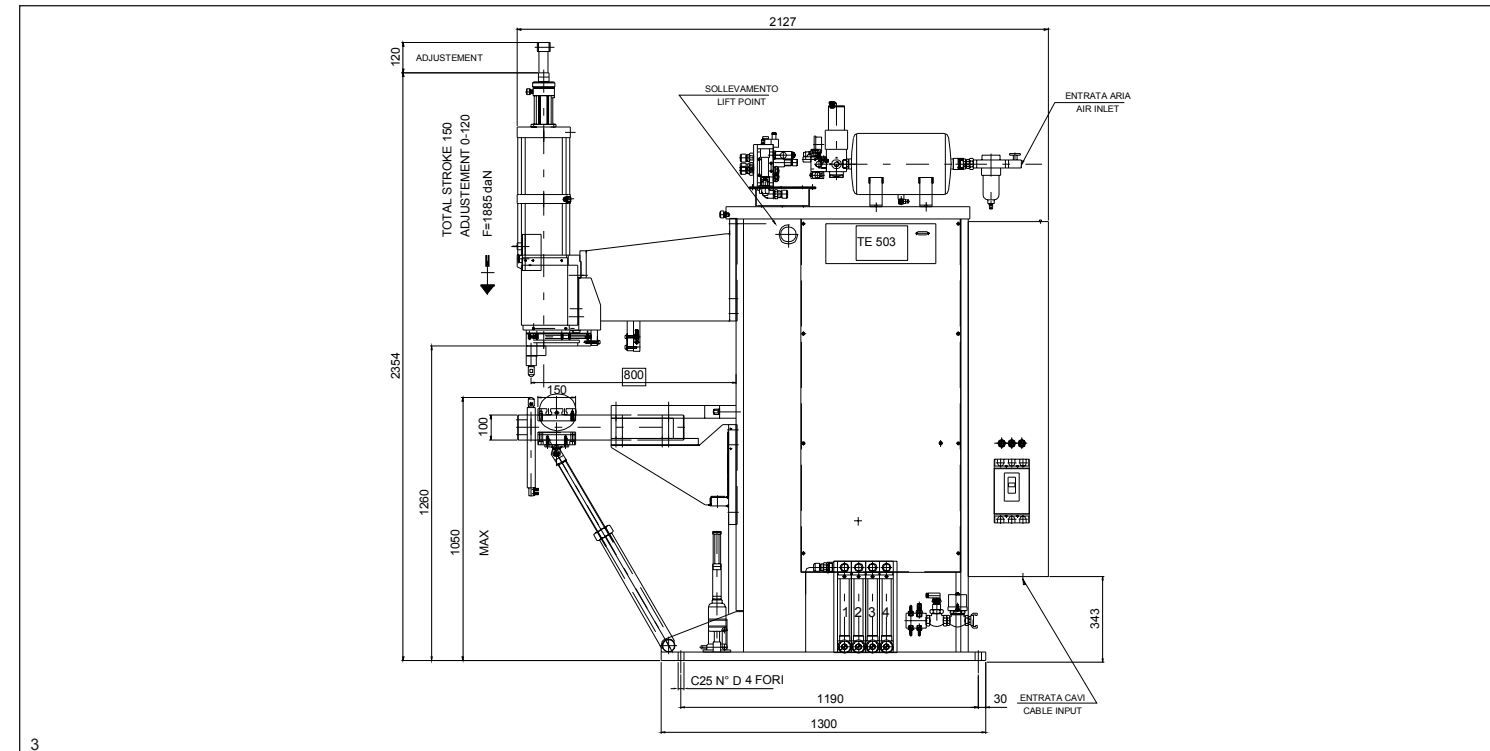

3