

# TECNA<sup>®</sup>

Resistance Welding Systems & Balancers

**3230÷3231**

PUNTATRICI PENSILI A MEDIA FREQUENZA  
MEDIUM FREQUENCY, AIR OPERATED SPOT WELDING GUNS  
MITTELFREQUENZ - PNEUMATISCHE PUNKTSCHWEISSZANGEN



CE

[www.tecna.net](http://www.tecna.net)

# 3230



Impugnatura standard  
Standard handle  
Standardgriff



Opz./Opt 3219



ARTICOLO ITEM ARTIKEL	POTENZA POWER LEISTUNG		INTERASSE GAP ACHSABST	FORZA MAX (6 bar) MAX FORCE (6 bar) MAX KRAFT (6 bar)	CORRENTE C.C. S.C. CURRENT KURZSCHLUSSSTROM	Ø INNESTO BRACCI ARMS FITTING Ø Ø EINSATZ ARME	BILANCIATORI BALANCERS FEDERZÜGE		PESO NETTO NET WEIGHT NETTO GEWICHT
	kVA al 20%	kVA al 50%					mm	daN (L=150mm)	
<b>3230</b>	<b>80</b>	<b>50</b>	<b>155</b>	<b>380</b>	<b>19</b>	<b>28</b>	<b>9366/B/RI</b>		<b>33</b>
PESO NETTO CON SOSPENSIONE E SENZA BRACCI - NET WEIGHT WITH SUSPENSION AND WITHOUT ARMS - NETTO-GEWICHT MIT AUFHANGUNG OHNE ARME									
N.I.= NON ISOLATI - NOT INSULATED - NICHT ISOLIERT									

# 3233



Impugnatura standard  
Standard handle  
Standardgriff



Opz./Opt 3219

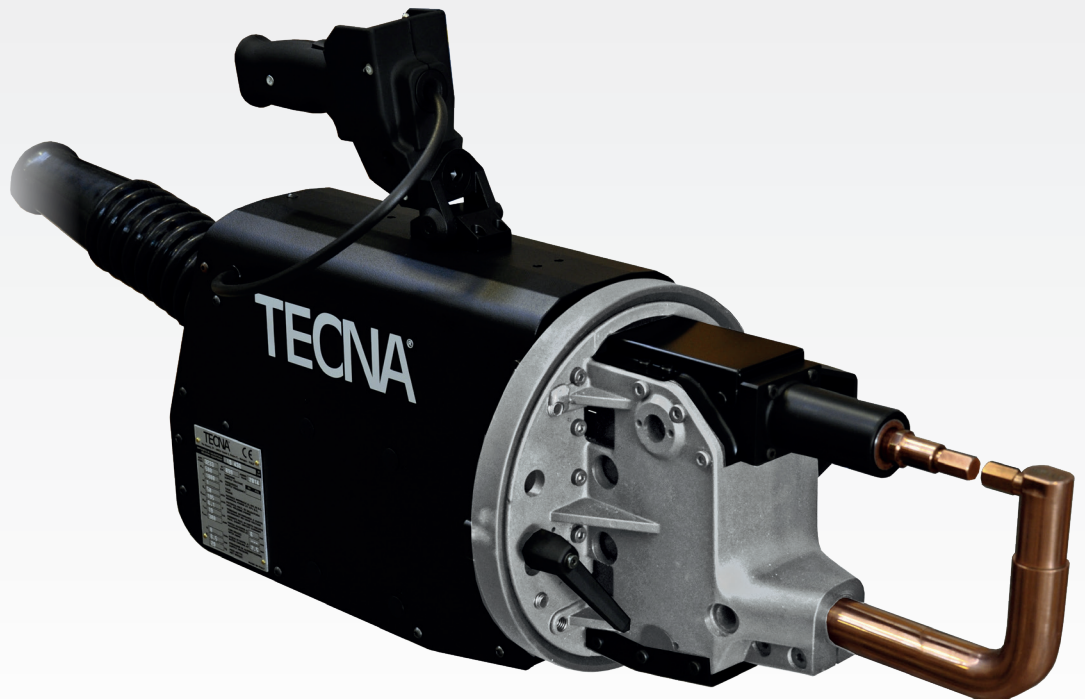

ARTICOLO ITEM ARTIKEL	POTENZA POWER LEISTUNG		INTERASSE GAP ACHSABST	FORZA MAX (6 bar) MAX FORCE (6 bar) MAX KRAFT (6 bar)	CORRENTE C.C. S.C. CURRENT KURZSCHLUSSSTROM	Ø INNESTO BRACCI ARMS FITTING Ø Ø EINSATZ ARME	BILANCIATORI BALANCERS FEDERZÜGE		PESO NETTO NET WEIGHT NETTO GEWICHT
	kVA al 20%	kVA al 50%					mm	mm	
<b>3233</b>	<b>80</b>	<b>50</b>	<b>--</b>	<b>300</b>	<b>19</b>	<b>34</b>	<b>9365/B/RI</b>		<b>29</b>
PESO NETTO CON SOSPENSIONE E SENZA BRACCI - NET WEIGHT WITH SUSPENSION AND WITHOUT ARMS - NETTO-GEWICHT MIT AUFHANGUNG OHNE ARME									
N.I.= NON ISOLATI - NOT INSULATED - NICHT ISOLIERT									

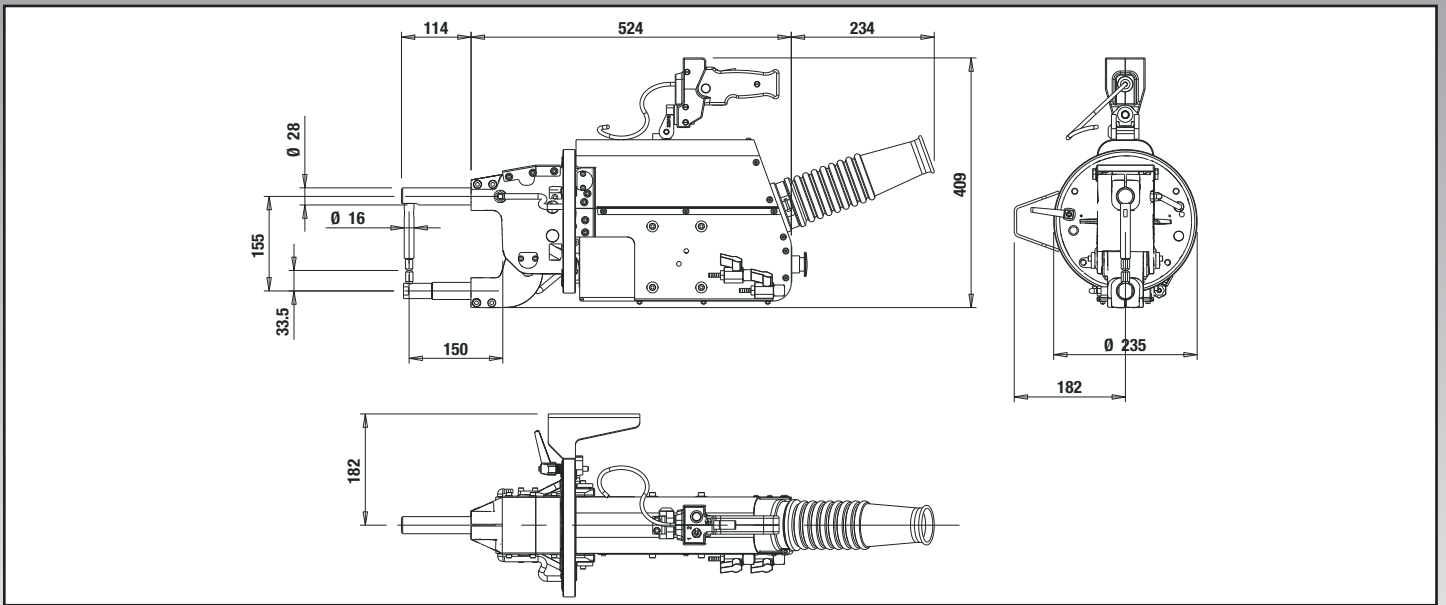

**Caratteristiche bracci / Arms features / Caractéristiques des bras / Daten der Arme / Características brazos**

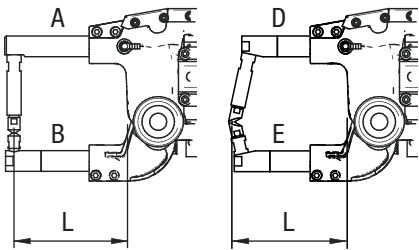

L	Bracci Arms Arme				*F	Peso coppia (circa) Set weight (approx.) Gewicht pro Paar (ungefähr)
	A	B	D	E	daN	kg
150	4780	4786	4801	4806	380	1,7
190	4781	4787	4802	4807	315	2,1
250	4782	4788	4803	4808	250	2,7
350	4783	4789	4804	4809	185	3,7
508	4784	4790	4805	4810	130	5,2

\* Forza agli elettrodi a 600 kP (6 bar) / Electrode force at 600kP (6 bar) / Effort aux électrodes par une pression de 600 kP (6 bars) / Elektrodendruck bei Vordruck 600 kP (6 bar) / Fuerza a los electrodos 600 kP (6 bar)

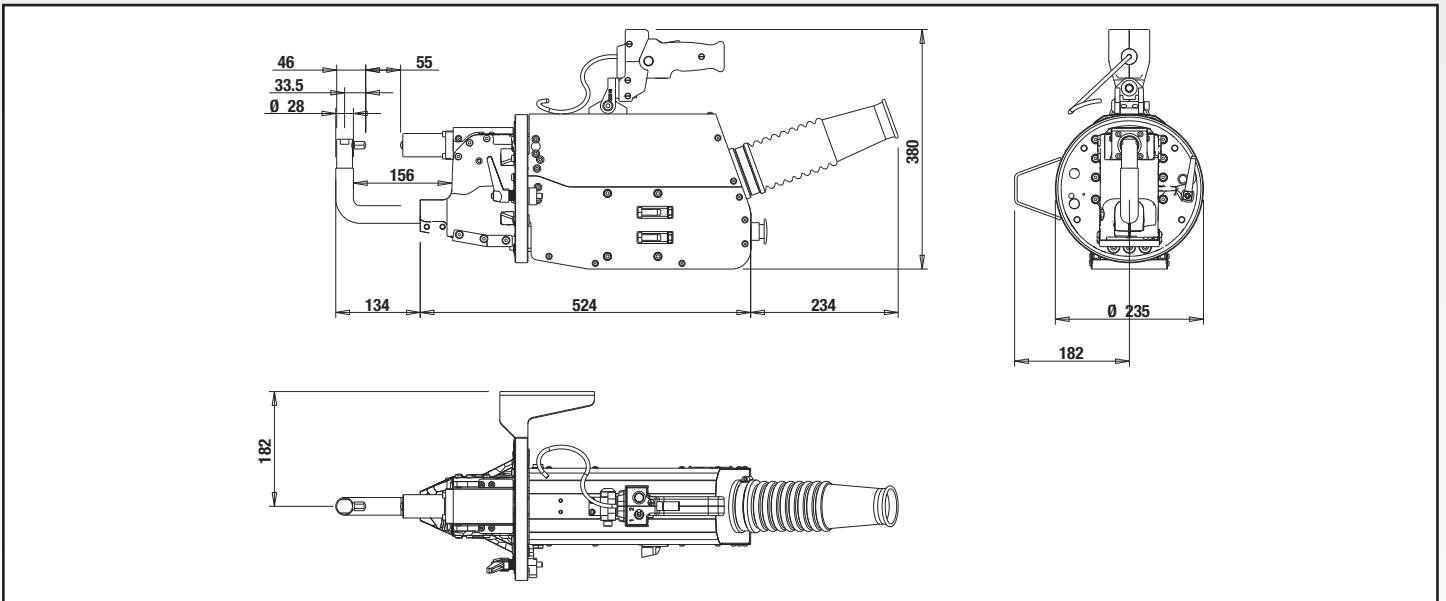

**Caratteristiche bracci / Arms features / Caractéristiques des bras / Daten der Arme / Características brazos**

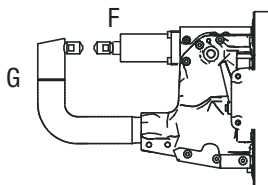

L	Bracci Arms Arme		Peso coppia (circa) Set weight (approx.) Gewicht pro Paar (ungefähr)
	F	G	kg
--	4799	4797	2,2

\* Forza agli elettrodi a 600 kP (6 bar) / Electrode force at 600kP (6 bar) / Effort aux électrodes par une pression de 600 kP (6 bars) / Elektrodendruck bei Vordruck 600 kP (6 bar) / Fuerza a los electrodos 600 kP (6 bar)



# 1591P



## ARMADIO DI CONTROLLO PER SALDATRICI A MEDIA FREQUENZA

L'armadio di controllo, che comanda la saldatrice a media frequenza, integra l'inverter, il controllo di saldatura TE770, i dispositivi di protezione e sicurezza. Sono disponibili diverse taglie, dipendentemente dalla potenza della saldatrice.

## CONTROLLO DI SALDATURA TE770

- Programmazione semplificata tramite 9 tasti e display grafico retroilluminato.
- Comando ad inverter a media frequenza.
- Funzioni di salita corrente, discesa corrente, pulsazioni, pre-saldatura, post-saldatura e regolazione dei tempi di saldatura con risoluzione 1 mS.
- Visualizzazione dell'RMS della corrente di saldatura e della percentuale di utilizzo della macchina.
- 2 modalità di funzionamento: corrente costante e FIX.
- Limiti in corrente e percentuale di utilizzo dell'inverter.
- Funzione incrementale per compensare l'usura degli elettrodi con curve programmabili.
- Comunicazione tramite porta USB. (Opzionale)
- Possibilità di visualizzare graficamente sul display tempo e corrente di saldatura.
- Possibilità di consultare alcune tabelle di saldatura.

## CONTROL CABINET FOR MEDIUM FREQUENCY WELDERS

The control cabinet, which controls the medium frequency welder, integrates the inverter, the welding control unit TE770, the protection and safety devices. There are different sizes available, depending on the power of the welder.

## WELDING CONTROL UNIT TE770

- Simplified programming by means of 9 keys and backlit graphic display.
- Medium frequency inverter control.
- Slope up, slope down, pulses, pre-weld, post-weld functions and adjustment of the welding times with 1 ms resolution.
- Display of the welding current RMS and of the use percentage of the welding machine.
- 2 operating modes: constant current and FIX.
- Welding current limits and inverter use percentage.
- Stepper function to compensate the electrodes wear with programmable curves.
- Communication via USB port. (Optional)
- Possibility of displaying the welding time and the welding current graphically.
- Possibility of consulting welding tables.

## ART. / ITEM 3218

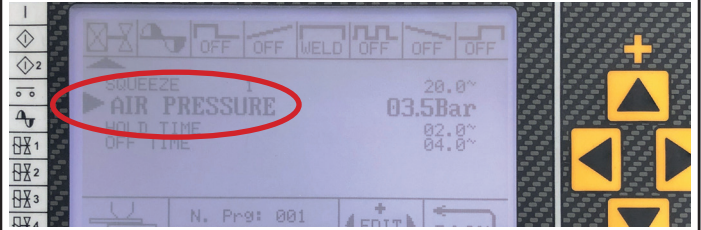

## VALVOLA PROPORZIONALE

Consente di regolare la pressione di lavoro direttamente dall'unità di controllo e di associare ad ogni programma il proprio valore di pressione. Garantisce una elevata precisione e costanza della pressione di lavoro.

## PROPORTIONAL VALVE

Allows to adjust the working pressure directly from the control unit and to combine a proper pressure value to each program. Assures constant and accurate working pressure.

## PROPORTIONALVENTIL

Ermöglicht die Arbeitsdruckeinstellung direkt auf der Steuerung und jedem Programm kann der eigene Druckwert zugeordnet werden. Gewährleistet Präzision und konstanten Arbeitsdruck.

## STEUERUNGSSCHRANK FÜR MITTELFREQUENZSCHWEISSMASCHINEN

Der Steuerungsschrank, der die Mittelfrequenz-Schweissmaschine steuert, integriert den Inverter, die Schweiss-Steuerung TE770, die Schutz- u. Sicherheitsvorrichtungen. Es gibt je nach Leistung der Schweissmaschine verschiedene Größen.

## SCHWEISS-STEUERUNG TE770

- Vereinfachte Programmierung mit 9 Tasten und Graphik-Display mit Hintergrundbeleuchtung.
- Inverter-Steuerung mit IGBT bei Mittelfrequenz.
- Funktionen Stromanstieg, Stromabfall, Impulse, Vor-Schweissen, Nach-Schweissen und Halbperiodenregelung der Schweisszeiten mit einer Auflösung von 1 ms.
- Anzeige des Schweissstrom-RMS-Wertes und des prozentualen Einsatzes der Maschine.
- 2 Betriebsarten: Konstantstrom und FIX-Strom.
- Stromlimit und prozentualer Einsatz des Inverters.
- STEPPERfunktion zum Ausgleich des Verschleisses der Elektroden mit programmierbaren Kurven.
- Kommunikation mittel USB-Port. (Optional)
- Möglichkeit der graphischen Anzeige von Schweisszeit und -strom auf dem Display.
- Möglichkeit zur Nutzung der Schweisstabellen.

La TECNA si riserva il diritto di variare senza preavviso alcuno, i propri prodotti. I Specifications subject to change without notice. I TECNA se réserve le droit d'effectuer des changements sans préavis I Technische Änderungen vorbehalten. I TECNA se reserva el derecho de efectuar cambios sin preaviso.

# TECNA®

TECNA S.p.A.

Via Meucci, 27 | 40024 | Castel S. Pietro Terme | Bologna | Italy

Tel. +39 051 695 4411 | Fax +39 051 695 4490

sales@tecna.net | vendite@tecna.net | www.tecna.net